

Table of Contents

General Overview.....	2-3
Specifications and Definitions.....	3
Error Messages.....	4
Product Temperature Compensation.....	4
Set Point and Loop Calibration.....	5
Program Flow Chart.....	5
Quick Steps.....	6
Programming of WCM 7300	7
Installation.....	7
Electrical Connections.....	8
Trouble Shooting.....	9-10
Dimensions.....	11

INVALCO Model 7300 WCM

The Model 7300 WCM is designed to:

- Accurately measure trace amounts of water in flowing hydrocarbon streams.
- Automatically compensate for reading changes caused by temperature variation of the flowing fluid.
- Display the information on a LCD readout.
- Provide an adjustable timed relay closure for control purposes and a 4-20 mA analog output for remote readout.

Calibration of the WCM 7300

The Model 7300 is calibrated by pressing the three buttons located below the LCD on the instrument front.

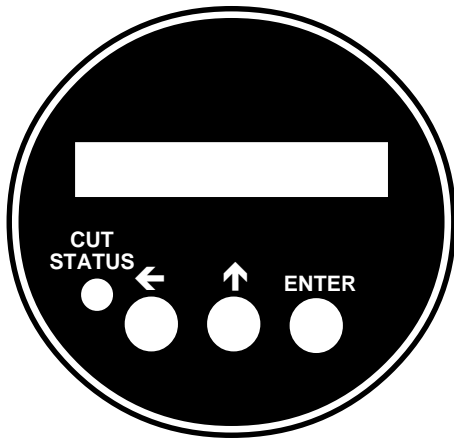

- The button on the left is pressed to scroll a flashing digit from right to left. It is to be pressed when the word "LEFT" or a left pointing arrow ←, is used in calibration.
- The button in the center is pressed to scroll a flashing digit to the next higher number. It is pressed when the word "UP", or an upward pointing arrow ↑, is used in calibration.
- The button on the right is pressed to enter information, or to move to the next item on the menu.
- The "CUT STATUS" light is an LED that can be green, red, steady, or flashing, depending on probe conditions.

After calibration, the LCD reading may be toggled by pressing the center UP arrow button or by momentarily placing the supplied magnet between the Model 7300 wording and the top electronic assembly mounting screw on the face plate. Use the button if the conduit cover is off; or the magnet if the cover is on. When toggled by either of these methods, the 7300 WCM will display the following:

1. Percent water cut in units, tenths and hundredths. It is normal and to be expected for the hundredth number to continuously move up/down following

minute changes in the chemical/physical composition of the hydrocarbon stream.

2. Temperature of the flowing stream. The readings can be changed from °F to °C by pressing the LEFT button. This can not be done with the magnet.
3. Electrical capacitance value of the probe in picofarads. Two readings are displayed. Ignore the one on the left which will be roughly 100 greater than the one on the right. The number on the right is the value of the probe as measured by the 7300. This is the value used by the electronics in analyzing the fluid stream. The number normally will be between 150 and 275 depending on the gravity of the oil, residual production/drilling chemicals, water cut, gas content, etc.

This reading can be valuable if you ever need to "trouble shoot" your system. It should be recorded at initial installation for future reference. It should be a steady reading. A change of .4 to .5 Pf will change the reading of the 7300 by .1%. If anything varies in the process stream making this reading fluctuate, the readings of the 7300 will also fluctuate as it follows the probe value.

General Information

The WCM 7300 is able to measure trace amounts of contamination by monitoring changes in the dielectric constant (Dk) of the process fluid. The probe functions as a large capacitor in the process stream with an inner pipe or electrode forming one plate of the capacitor and the outer pipe forming the other plate of the capacitor (Figure 1). Oil and water both have dielectric properties, however, their dielectric constants are very dissimilar. Oil typically has a Dk of $2.0 \pm$ and water has a Dk of 80. The dielectric properties cause the probe to act like a small battery. The amount of energy stored in the probe is a measure of the dielectric capacity or capacitance. As water contamination occurs, the Dk of the oil changes, altering the capacitance of the probe.

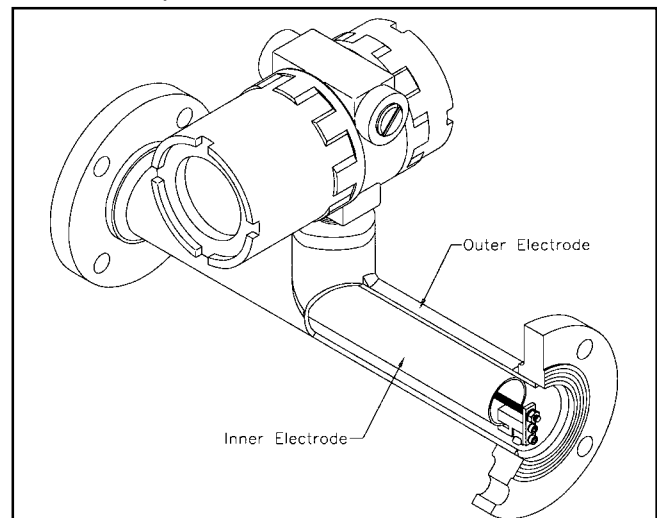

Figure 1

By placing a small amount of high frequency alternating current on the probe inner electrode, it is possible to detect changes in the dielectric. Knowing the area of the electrodes and the Dk of the oil, it is possible to determine the capacitance of a probe when full of clean oil or other hydrocarbons. Should the oil become contaminated with water, changes in the capacitance are displayed as a percent contamination of the oil.

Specifications

Temperature

Unit: -4°F to 158°F (-20°C to 70°C).

Process (Oil): 32°F to 160°F (0°C to 71°C).

Power

18 to 32 Vdc (24 Vdc nominal) at 250 mA maximum.

Range of Dielectric Constant (Dk)

1.7 to 5.0

Accuracy

Is defined as the amount of variance observed between the 7300 reading and the water grindout of the oil flowing through the probe.

Normal variances are:

±.05 From 0 to 5% water cut.
±.1 From 5 to 10% water cut.
±.15 From 10 to 15% water cut.

Output

Display: 16-character alphanumeric

Relay: SPDT rated 10 Amp at 24 Vdc.

4-20 mA: Loop powered.

Isolated to ±4 Volts Common Mode.

Enclosure

NEMA 7 explosion-proof, Class I, Division 2, Group C and D.

Process Connections

Flange, grooved, MNPT.

Definitions

Cut - A term commonly used to describe the % water by volume in the product stream.

S&W - The term S&W is referring to water and other contaminants in the hydrocarbon (oil) product stream.

Grindout - A test performed on an oil sample to determine % water by volume. This is normally by centrifuging, but may be done by other methods.

TC - Temperature coefficient for temperature compensation of the oil.

Dk - Abbreviation for dielectric constant.

Dielectric Constant - An electrical property of all materials which (in this case) is used to differentiate between water and oil.

Display Definitions

There are many messages used to communicate information on data entry. The messages are summarized in the following:

Program Mode - To enter program mode, press all three buttons simultaneously.

Program Mode - To enter the calibration menu, press the buttons in the following sequence. "Left, Left, Left, Up, Up." If entered incorrectly, the display will revert to the "20mA =" menu. If this is the case, press Enter until the unit is in normal operating mode (displaying "Cut %" or a range error message) and start over.

Last Cut XX.XX% - This provides information only, telling what cut was entered at the last calibration.

Do Cal? YN - Pressing the left arrow will toggle the flashing cursor between N and Y. Selecting Y and then Enter commits you to making a grindout or cut entry. N will put you into the Manual TC Entry Mode.

Cal With X Cut - Pressing the up arrow allows selection of either one or two cuts. Select 1 for one-cut calibration. Select 2 for two-cut calibration with auto TC.

Enter Cut X.XX% - Enter cut or grindout value for calibration.

Manual TC = XXXX - Displays TC value for temperature compensation. Suggested default is 600 (for 5% units). Use zero if no temperature compensation is desired.

Auto Set TC YN? - Use with second cut. Select Y to proceed with an automatic calculation on the TC value. Selecting N will leave the TC value unchanged.

Auto Set TC = XXXX - Resulting TC value from a TC calculation.

Auto Set Fail/Cuts Too Similar - An advisory message which tells you that the Auto Set TC was not successful due to the two temperatures being too close together or that the cut or grindout information does not agree with the type of change expected for oils. For example, the dielectric constant of the oil should decrease with an increase of the temperature. If the cut information does not match this behavior, it is deemed invalid and the Auto Set TC operation will not be accepted.

Note: *If unit responds with this error after a second attempt to Auto Set the TC value, recheck sample to see if water cut has changed.*

20 mA = % - Allows the span of the 4-20 mA loop and the 0-5 Vdc output to be set. The 0-5 and 4-20 are directly linked so that 4 mA is the same as 0 Vdc and 20 mA is the same as 5 Vdc. The 20 mA point is always considered the % water where 20 mA will be produced. It is not useful to enter a number greater than the unit range.

Set Pt =% - The setpoint value is that value at which the setpoint relay will go to bypass. This is the same as the power off relay position, i.e., the NC contact is closed. The delay value establishes how long the instrument observes a bad oil condition before actually releasing the relay to bad oil. During this time, the red LED on the front panel will flash. At the relay release, the flashing will stop and go to solid red. When in transition from bad

oil to good oil, the reverse is true. The green LED will flash until the relay engages, then the LED will go to solid green.

Delay = Sec - Related to the setpoint, this value establishes the number of seconds of delay between a bad oil condition (red LED flashing) and release of the relay to bypass (solid red LED). The reverse condition (green LED and transition to good oil) will occur in 1/10th the delay time.

Undo Changes? YN - This allows the opportunity to reverse or undo all calibration changes made during the past programming session. The selection is automatically N, unless Y is deliberately selected. Y should be used after an Auto Set Fail and prior to attempting Auto Set TC again.

Program Done - No action is required here. This is an advisory message telling you that you have finished the programming modes. You only need to press Enter to go into normal operation.

Error Messages

The INVALCO WCM 7300 continuously calculates a water cut based on a variety of control parameters. If any of these parameters are out of range or are inconsistent with known fluid Dk properties, advisory messages will result. These messages and their meanings are stated below.

Under Range - The probe value is below the range established for the dielectric constant (Dk) and /or the range of the instrument. A standard WCM 7300 has a Dk tuning range of 1.7 to 5.0 which encompasses a wide range of crude oils and refined products. If the probe value is low due to a low Dk, gas breakout in the oil, probe not completely full, etc., the Under Range message will result.

Auto Set Fail/Cuts Too Similar - This advisory message only can occur in a Method 2 calibration where you are asking the unit to automatically calculate the TC value. The WCM 7300 requires that two cuts be used, the first being from a previous Method 1 calibration.

This message can occur if the temperature information does not match with the Dk change. The Dk must drop with an increase in temperature. If this did not occur by virtue of the type of cuts given, then the calibration is considered invalid; no changes will occur, and the unit will display this message.

A second possibility is that the temperature of the first and second cuts are so close that a calculation cannot be made. A minimum product temperature change of 5°F is required.

Below Cal Zero - This is a message that will be displayed if the value of the probe goes below the calibrated zero point. The LED will stay green.

Over Range - This message will appear if the probe is shorted, full of water, the insulators are coated with a conductive material, or anything that might produce a low resistance reading from the probe center stud to ground.

Check Probe Wire - This message advises that the lead from the electronics to the probe is loose.

Product Temperature Compensation

The base Dk of oils can change radically with changes in temperature resulting in a reading change that appears to be a water cut change, when, in fact it is a Dk shift due to temperature. For example, for a 10°F change a typical crude oil may show a reading shift of as much as 0.1% which would be interpreted as water, not a temperature change. The WCM 7300 measures product temperature and by looking at temperature as well as water cut calculates a corrected cut reading, thus providing a true S&W cut over a wide range of temperatures.

There are two ways to calibrate the WCM 7300 to provide this temperature compensation (T.C.).

1. Manually enter an "average" T.C. number from the chart below.
2. Have the WCM 7300 automatically calculate the T.C. value.

Method 1. Manual T.C. (One Cut)

During programming the instrument will display "Manual TC =" when displaying the TC value in use. Enter the default value from the table below or enter some other value, such as a value known to work on other installed WCM's in the same field or with similar crudes. Please note that the temperature compensation is only as accurate as the value used, however, use of an approximate TC value will still improve accuracy by an impressive amount. Remember, all oils change dielectric constant inversely with temperature and any compensation will help to defray this effect. If estimating a TC value, estimate low so that you do not over-compensate.

600 for 5% Unit
450 for 10% Unit
200 for 25% Unit

Method 2. Auto T.C. (Two Cuts)

This method uses two different cuts and temperatures to automatically determine the TC value for your oil. You first calibrate with one cut and then calibrate a second time with a second cut. The 7300 "looks" at the two water cuts and two temperatures. It then calculates a temperature compensation value for that particular oil.

Note: The second cut must be at a higher temperature and the water content equal to, or lower than the first cut.

A minimum temperature increase of 5° F is required for the instrument to perform the Auto TC calibration.

If the temperatures are too close or the cuts are invalid combinations, the instrument will not perform the TC calculation and will advise you that a problem exists by displaying "Auto Set Fail/Cuts Too Similar."

When to Use Method 1:

1. For first time calibration.
2. When temperature changes exist, but additional grindouts are not possible, or practical, at other temperatures.

When to Use Method 2:

1. When a second cut is possible at a different product temperature. All oils change with the temperature, no two oils change quite the same. Some may change very little while some may change considerably.

If real close measurement is not required, then the effects of temperature changes may not be a

factor. But, it can be very important in cold climates where the maximum amount of water pipelines will accept is often less than .5%. In these cases, every possible variant must be considered and controlled where possible. Reducing or removing the detrimental effects of temperature changes can often be the difference between success or failure of an installation.

Set Point and Loop Calibration

The set point, delay, and loop span values are established during programming. It is possible to adjust these values without entering into the cut and TC calibration programming. Entry of these values is described in detail in the following sections.

Below is a flow chart programming guide. Each bubble or diamond represents what the display will show. The information adjacent to the small circles between the bubbles instruct you on how to proceed through the programming modes.

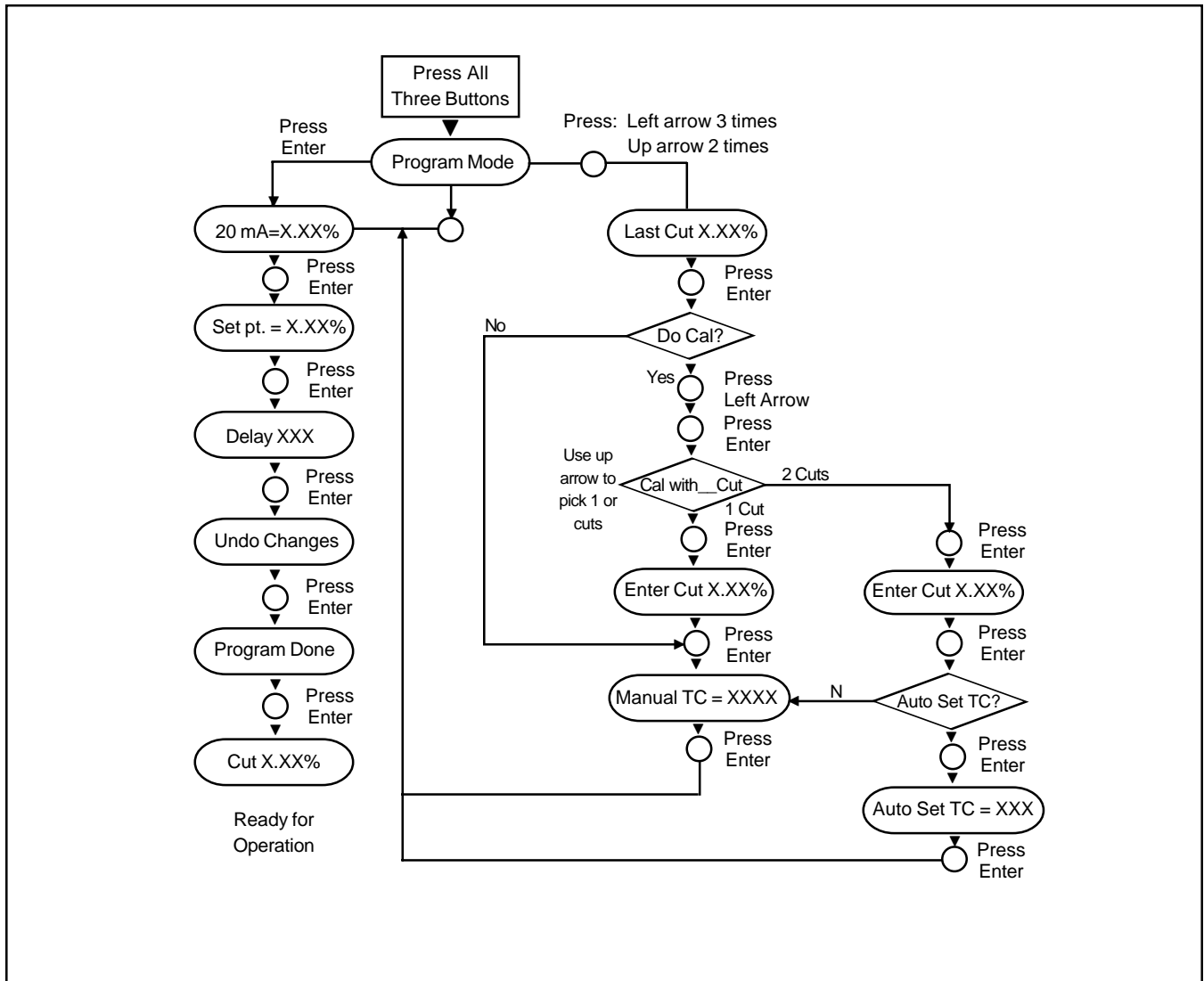

Figure 2

Quick Steps for Putting Your WCM 7300 Into Operation

Mechanical Installation

For best results, install the probe with the following requirements:

- Probe is in a vertical piping section (in-line probe only).
- Flow is from bottom to top (in-line probe only).
- If probe is installed on a pressure vessel, the probe must be installed in piping prior to dump valve.
- Air or gaseous content is minimized.

Note: The probe must be full of oil for proper operation.

Caution: Operating the instrument while the probe is empty or partially filled will not damage the instrument, however, invalid readings or under-range indication will occur.

Electrical Installation

Connect 18-32 Vdc to the terminal block inside the back (non-windowed) cover of the instrument. The power connections are marked "+24V" and "24V GND".

Note: For initial operation, only power is required. The LCD display will provide the necessary information to verify operation. To connect the analog outputs and/or the relay alarm, refer to the detailed section on electrical connections.

Field Calibration

The WCM 7300 has been factory tested, however, it **must** be field calibrated as follows.

Warm Up

Apply power to the WCM 7300. Allow the instrument to be powered for at least 10 minutes before calibrating the unit.

1. Bring system into operation with normal flow through the probe. Allow the temperature to stabilize.

Note: Since the unit is not yet field calibrated, Error advisory messages may flash on the display. Ignore these until after calibration.

2. Take a grindout for water in the oil. For calibration purposes, the oil should preferably have less than 1% water in it.
3. With the condulet cover removed, depress all three buttons at the same time.
4. When the display reads Program Mode, release the buttons. You are now in programming mode.
5. Press the Left Arrow button three times and then the Up Arrow button twice.
6. The unit should be displaying Last Cut x.xx% where x.xx is the Cut Value used for the last calibration. Ignore this for now.

Note: If you entered the sequence in Step 5 incorrectly, the display will be reading something different. To start over, press Enter until past the display that says Program Done. Then restart at Step 3.

7. Press Enter to proceed to the next display.
8. The display will now say "Do Cal? YN". The N should be flashing (meaning no). Select Y (yes) by pressing the Left Arrow key. The Y will now be flashing.
9. Press Enter to confirm yes and proceed to the next display.
10. The display should now read "CAL with X CUT" where X is 1 or 2. The number will be flashing. Pressing the Up Arrow key will toggle the number between 1 and 2. Select 1 if this is the initial calibration. Select 2 if you are entering the second cut for Auto TC. (See pages 4 and 5.)
11. Press Enter to proceed to the next display.
12. The display will now be reading "ENTER CUT x.xx%" where x.xx is the cut value to be used for calibration. Press both the Up Arrow and the Left Arrow keys at the same time to zero the display. Using the Up Arrow and Left Arrow keys, enter the grindout value (in the x.xx positions) obtained in Step 2 above.
13. Press Enter to accept the Cut and to Proceed to the next display.
14. The display will now read "Manual TC = xxxx, where xxxx is some number. This is the temperature compensation (TC) factor. It is what sets the temperature compensation for Dk changes with temperature. If you want no compensation, enter 0, otherwise, enter 600 for a 5% unit, 450 for a 10% unit, and 200 for a 25% unit.
15. Press Enter to accept the TC and proceed to the next display.
16. The display will now read "20 mA = xx.xx%". Where xx.xx is the full scale span desired for the 4-20 mA loop. 4 mA will always be equal to 0.00% water, and the 20 mA value is equal to the water % entered here. Enter the value desired by using the up and left arrow keys. Press "Enter" to accept the 4-20 mA span and to proceed to the next display.
17. The display will now read "Set Pt = x.xx%". This is the water cut value at which the relay and indicator light go to bad oil as shown by the indicator light blinking red. Enter the value with the Up Arrow and Left Arrow buttons.
18. Press Enter to accept the setpoint and to proceed with the next display.
19. The display will now read "Delay = xxxx Sec." This is the number of seconds the unit will allow bad oil until the relay goes into bypass. Enter the desired value with the Up Arrow and Left Arrow buttons.

20. Press Enter to accept the delay and to proceed to the next display.
21. The display will now read "Undo Changes? YN" with the N flashing for no. The Left Arrow will toggle the cursor between Y and N. Selecting Y would undo all information entered in this programming session and restore the unit to all conditions prior to entering the programming mode. Leave the selection at "N".
22. Press Enter to accept all of the settings and to proceed to the next display.
23. The display will now read Program Done.
24. Press Enter to leave the program mode.
25. The LCD will now display the grindout value entered unless the cut has changed during calibration. If so, the value displayed will be the new value and not the value entered.

Normal Operation

The WCM 7300 is now displaying water cut in % water. The Up Arrow button will toggle the display between Cut in %, temperature and probe electrical value. You can toggle the readings by pressing the center up arrow button or using the supplied magnet. The Temperature readings can be changed between °C and °F by pressing the Left Arrow button.

Bypass Relay and Indicator Lights

As stated above, the setpoint entry establishes the point at which a cut value becomes a bad oil reading. The programmed delay sets the delay, in seconds, between a bad oil condition and relay release. The indicator LED is green when the cut is below the setpoint, and red when at or above the setpoint. When the LED flashes red, the setpoint is exceeded, but the delay time has not expired. When the relay goes to bypass (delay is over), the LED will go to solid red. The same applies when going from bypass to good oil, with the LED flashing green and then going to solid green.

Installation

Caution: The conduit is secured in place by an allen head set screw in the hub where the conduit is attached to the probe. The conduit must not be rotated. Calibration can be affected and unit damage may also occur (See Figure 3).

Probe Installation

It is recommended that the probe be mounted in a vertical section of the process piping with the flow upwards through the probe. Trapped air and gases will cause dramatic changes in the reading due to the high differential of the Dk values between air (or gas) and oil. This problem is greatly reduced with vertical probe orientation.

Note: Water contamination in oil can take several physical forms, such as small droplets, slug, or larger "globs" of emulsion. The WCM 7300 will provide the best indication of contamination in the process stream if the water is well dispersed.

Electrical Considerations

The WCM 7300 is housed in a NEMA 7 explosion-proof enclosure and may be located in any Class I, Division 2, Group C and D environment. The unit requires 24 Vdc, 250 mA at 3.6 Watts (Figure 3).

It is possible to install the analog loop as isolated (using an external power supply to power the loop) or non-isolated (using the 24 Vdc on the unit to power the loop).

Note: When isolated, the two power supply returns can be allowed to have a maximum difference of 4 Vdc. (See Page 8).

Note: The unit is not powered by the 4-20 mA loop connection.

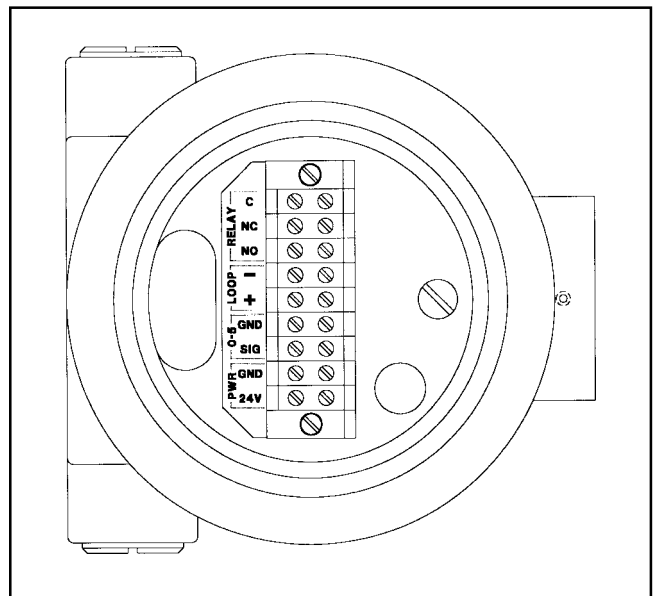

Figure 3

Programming

As with any microprocessor-based measuring device, certain process and control values must be entered into the memory. These values customize the unit for specific customer needs and applications. Information needed is:

- Span of 4-20 mA.
- Relay actuation setpoint.
- Setpoint time delay.
- Cut calibration (grindout value).
- Temperature Coefficient (TC).

All these values may be entered with three buttons located on the WCM front panel.

All three buttons are used to program the unit.

Electrical Connections

To connect the input power (Figure 4):

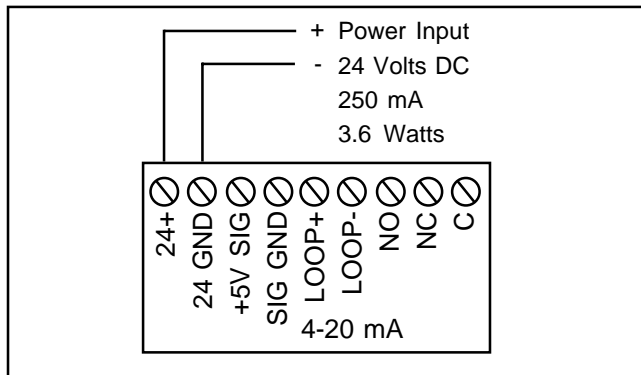

Figure 4

Connect 24 Vdc to the unit with the “+” wire going to the 24+ Terminal and the “-” wire going to the 24 GND Terminal.

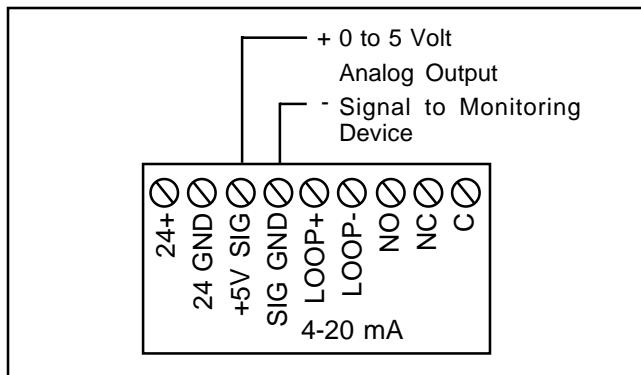

Figure 5

To connect the analog voltage output (Figure 5):

Connect the analog 0 to 5 volts with the “+” on the 5V SIG Terminal and the “-” on the SIG GND Terminal.

Note: This signal tracks the 4-20 mA output and is not adjustable.

To connect the 4-20 mA analog output as isolated (Figure 6):

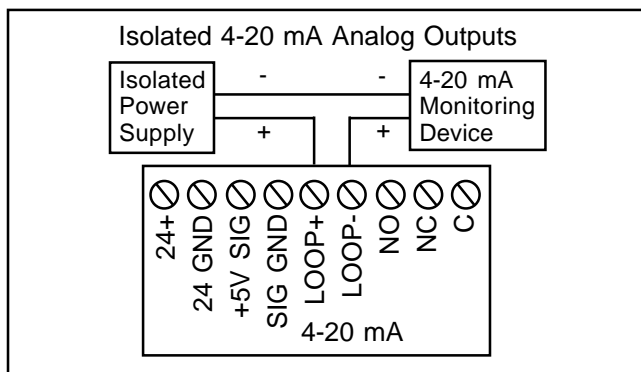

Figure 6

Connect the “+” terminal of the monitoring equipment to the Loop “-” Terminal. Connect the “-” terminal of the monitoring equipment to the “-” terminal of the power supply. Connect the “+” terminal of the power supply to the Loop “+” Terminal.

To connect the 4-20 mA analog output as non-isolated (Figure 7): Install a jumper wire from 24V+ to Loop+.

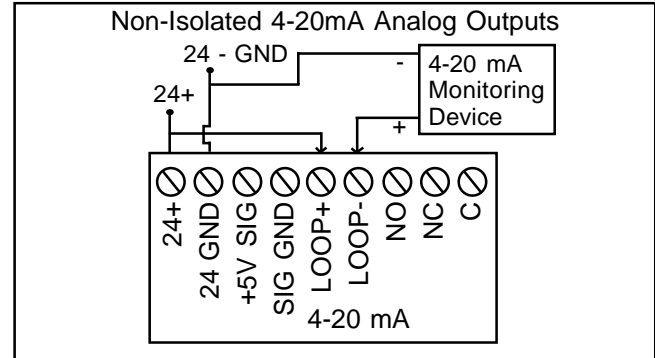

Figure 7

Connect a jumper wire from the 24 “+” Terminal to the Loop “+” Terminal. Connect the Loop “-” Terminal to the “+” terminal of the monitoring equipment. Connect the “-” terminal of the monitoring equipment to the 24 GND Terminal.

Note: The 4-20 mA loop circuit must be powered as either internal (non-isolated) or external (isolated) or it will not produce the 4-20 mA analog output.

The SPDT relay is labeled with terminals marked “Relay”.

To connect the 10 Amp SPDT relay (Figure 8):

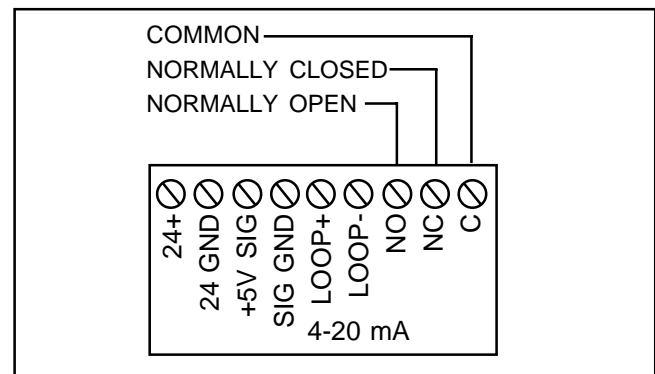

Figure 8

The Normally-Open Terminal is labeled “NO”, the Normally-Closed Terminal is labeled “NC”, and the Common Terminal is labeled “C”.

When the unit is on, the relay is energized and the connection is made between common (C) and normally-open (NO). In alarm or bypass conditions, or power failure, connection is made between common (C) and normally-closed (NC).

Troubleshooting

1. The 24 volt power supply to the 7300 must be good, steady, and ripple free. Half wave rectifier sources normally are not acceptable, producing unreadable displays.
2. If the RTD (Resistance Temperature Device) that measures the fluid temperature should “short” or “open” the 7300 will continue to operate, but will lose its temperature compensating ability. The RTD is located at the bottom of the hollow stud that comes up into the conduit from the probe. The stud is the 3/8” threaded rod onto which you attach the probe clip wire from the electronic assembly. To remove the RTD, you first remove the electronic assembly and then pull the RTD out by the cable going into the hollow stud. The RTD is coated with a white heat transmitting grease. Wipe the grease off and transfer it onto the new RTD before installing it.
3. If the water cut reading drifts, but the shakeouts show the cut to be constant, check the temperature and probe readings from the LED display. Stop the fluid flow through the probe to see if the reading stabilizes. If it does, then the problem is flow related, and could be caused by any of the following:
 - a. If the temperature is varying, and you are on manual TC, you may need to:
 - (1) Go to the two cut method and let the 7300 calculate it’s own temperature compensation factor.
 - (2) Change the manual TC number. The 600 number is a TC that normally is good for most oils, but may not be for yours. If the indicated water cut goes up with an increase in temperature, the manual TC number is too high and should be reduced. Since all oils vary in their reaction to temperature changes, it is not possible to say how much reduction in TC is needed. Some experimenting may be required. Conversely, if the indicated cut goes down with a temperature increase, you need to increase the TC value.
 - b. If the probe value is varying, look for:
 - (1) An increase in the API gravity of the oil. This will cause the value to go down. Conversely, a decrease in API gravity will cause the reading to increase. This is not a linear function, and varies from oil to oil, but generally is consistent.
 - (2) A variation in the amount of solution gas in the oil.
 - (a) NEVER mount a probe down stream of the dump valve when monitoring oil from a pressure vessel as solution gas will break out as the fluid goes from the higher vessel pressure to the lower pressure downstream of the valve. An increase in gas will make the reading become smaller. Also, since the size and volume of the gas bubbles is constantly changing with flow, the probe value can be very unstable as it attempts to follow the fluctuating gas content.
- (b) A change in pressure on the oil as the divert valve switches from “good” to “bad” oil on a LACT. Switching to a higher pressure bad oil line can make the 7300 read higher. Switching to a lower pressure can make it read lower. For good operation, the pressure must be kept constant to keep the solution gas bubble size constant. Please note that air eliminators will vent slugs of gas, but not solution gas.
- (3) A change in chemicals, of either volume, type or supplier. Remember that the probe looks at/checks everything that flows through it including chemicals, stuffing box rubbers, oil, water, minerals, etc. Changing chemical conditions normally cause the greatest trouble as it is easy to forget that they can affect the Dk of the stream and, hence, affect the readings. Normally an increase in chemical will cause the readings to increase. However, just changing types and/or suppliers usually will require a recalibration after the system has stabilized.
- (4) Other things that can cause troubles are:
 - (a) Having loose fitting on the suction side of the pump that is pumping the fluid through the monitor probe. The pump will suck in air causing the oil to act as if it had gas in it.
 - (b) Mounting the probe directly on the pump discharge. This will/may be ok as long as the pump has plenty of suction head, is not over speeding, has the proper impeller, etc. But the possibility for trouble always exists.
 - (c) Mounting the probe directly to a static mixer. A static mixer functions by mixing (as violently as possible) the fluid going through it. The fluid exiting the mixer is normally still full of bubbles and will cause erratic readings. If the mixer has been installed backwards, the results are disastrous.
- (5) Probe Problems
All internal “wetted” parts of the probe are either teflon or coated by a baked on epoxy. Normally a probe will give many years of service without any problems. However, chemicals added to the process stream often will cause a conductive film to coat over the teflon insulators and the

epoxy coating causing much trouble.

Often you can check for this without removing the probe from the line by doing the following:

- (a) Actuate the center Up ↑ button on the 7300 until the valve of the probe is displayed. It is the number on the right. Any valve over 250 pF is suspect.
- (b) Remove the 24 volts power to the 7300. Remove the two screws holding the electronic assembly into the conduit. Gently pull the electronic assembly out, and to the side, so you can disconnect the clip from the electronics to the probe center stud.

(1) Measure the resistance from the center stud to the conduit - or some other grounded object. The resistance should be infinity. Any reading less than 250,000 ohms is bad.

(2) Switch the V-O-M to low range D.C. volts. Check for voltage from the center stud to ground. The voltage should be zero. Any voltage higher than .25 volts is bad.

If you observed questionable reading in any of the three above checks, the teflon insulators are beginning to either be coated, or slightly impregnated by chemicals and need to be replaced or cleaned.

More Comments on Error Messages

The LCD will read "Check Probe Wire" if the lead from the electronic assembly to the probe is loose, not attached, or the probe is empty. The LED will blink red for the amount of time delay set in the unit, and then go solid red. At the same time the relay will actuate. If you press the center button to the probe value position, the number in the right position will be up around 360.

If the unit is in operation and the Dk of the fluid going through the probe falls, the LCD will go to 0.00. If the Dk continues to fall the LCD will flash "Below Cal Zero". The LED will stay green and the relay will stay in the good oil position. You may be able to reprogram and recalibrate from the "Below Cal Zero" reading, but the center push button/magnet will not operate as long as the "Below Cal Zero" signal is flashing. If you try to recalibrate and the Dk is too low, the 7300 will read "Cut Fail" indicating that the probe value is too low for calibration and that the instrument will go into "Under Range" if the value goes much lower.

If the Dk should continue to drop causing the probe value to decrease even further, the "Under Range" message will come on. The LED will blink red for the time delay setting and then go solid red. The relay will actuate to the "oil by passing" position. Note that the probe value numbers (that you can bring up on the LCD) become invalid anytime the "Under Range" message is showing.

If the probe's electrical value keeps falling the unit will go to "Check Probe Wire"

The LCD will read high water cut values or "Over Range" if the probe is full of water, has a conductive buildup (such as some corrosion inhibitors) covering the insulators, is shorted, etc.

Dimensions

Inches (mm)

Assembly No.	Probe Size	Dimensions - Inches (mm)						
		A	B	C	D	E	F	G
81017222	2" 150#	17.0 (432)	8.5 (216)	4.5 (114)	4.5 (114)	8.0 (203)	5.3 (135)	8.0 (203)
81017232	3" 150#	32.0 (813)	16.0 (406)	4.5 (114)	4.5 (114)	8.0 (203)	5.3 (135)	8.3 (211)
81017242	4" 150#	32.0 (813)	16.0 (406)	4.5 (114)	4.5 (114)	8.0 (203)	5.3 (135)	8.8 (224)
81017262	6" 150#	32.0 (813)	16.0 (406)	4.5 (114)	4.5 (114)	8.0 (203)	5.3 (135)	9.9 (251)

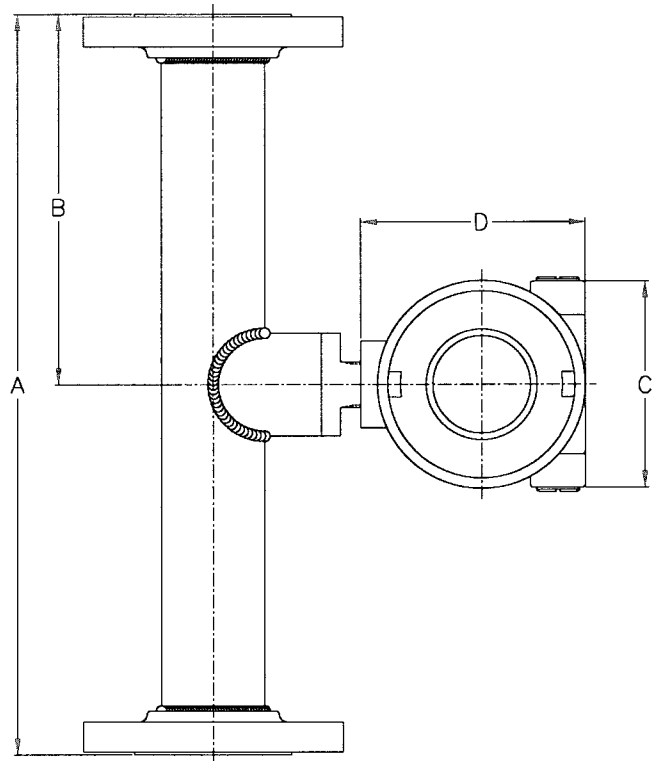
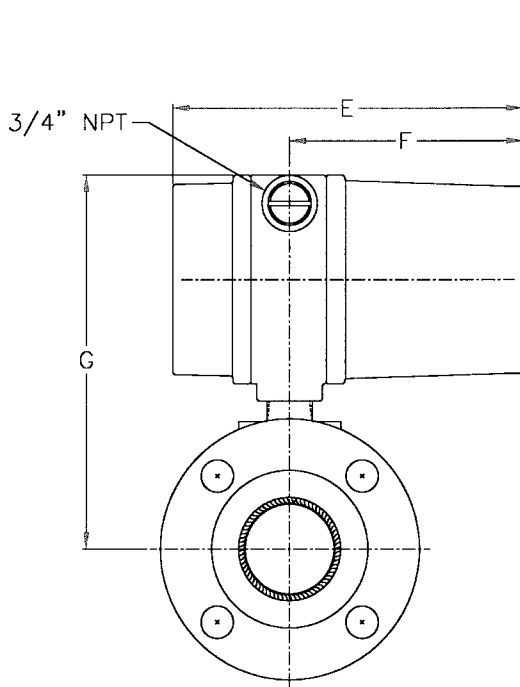

Note: Dimensions - Inches to the nearest tenth (millimeters to the nearest whole mm).

The specifications contained herein are subject to change without notice and any user of said specifications should verify from the manufacturer that the specifications are currently in effect. Otherwise, the manufacturer assumes no responsibility for the use of specifications which may have been changed and are no longer in effect.

FMC INVALCO Fluid Control P.O. Box 1377, Stephenville, TX 76401, Phone: 254/968-2181, FAX: 254/968-5709, Toll Free: 800/468-2526

Printed in U.S.A. ©10/00 FMC INVALCO All rights reserved. Issue/Rev. 0.2 (10/00)