



ACCESSORIES







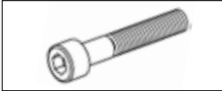
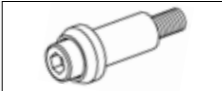
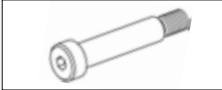
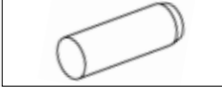

MDL

OCTOBER 2017

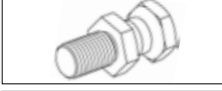
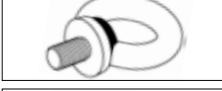



ACCESSORIES CONTENTS

■ Socket head cap screws	A05		3
■ Stripper bolts	A15		4
■ Shoulder screws	A17		5
■ Dowel pins	A20		6
■ Dowel pins	A25		7
■ Lifting lugs	A30.010		8
■ Collar eye bolts	A30.012		8
■ Swivel lifting rings	A30.013		9
■ Lifter studs	A30.015		9
■ Location bolts	A30.02		10
■ Threaded plugs	BRM.V1		10
■ Compression pads	A50		11
■ Lifting bolt	A32		11
■ Band Guide and Lifter kit			12

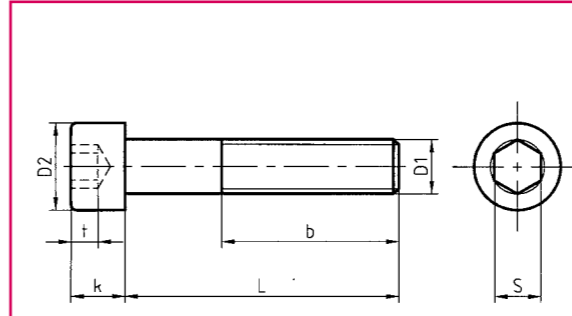

Conforms to : NF EN ISO 4762
 Material : Steel
 Strength : Category 12.9
 : Mini 1200 N/mm²

Ordering example

M8 L=50 hexagon socket head cap screw

Please state: Réf. A05.008.050

D1	M3	M4	M5	M6	M8	M10	M12	M16	M20
D2	5.5	7	8.5	10	13	16	18	24	30
b	18	20	22	24	28	32	36	44	52
k	3	4	5	6	8	10	12	16	20
t min.	1,3	2	2,5	3	4	5	6	8	10
S	2,5	3	4	5	6	8	10	14	17
L	Reference								
8	A05.003.008	A05.004.008							
10	A05.003.010	A05.004.010	A05.005.010						
12	A05.003.012	A05.004.012	A05.005.012	A05.006.012					
16	A05.003.016	A05.004.016	A05.005.016	A05.006.016	A05.008.016				
20	A05.003.020	A05.004.020	A05.005.020	A05.006.020	A05.008.020	A05.010.020			
25	A05.003.025	A05.004.025	A05.005.025	A05.006.025	A05.008.025	A05.010.025	A05.012.025		
30	A05.003.030	A05.004.030	A05.005.030	A05.006.030	A05.008.030	A05.010.030	A05.012.030		
35		A05.004.035	A05.005.035	A05.006.035	A05.008.035	A05.010.035	A05.012.035	A05.016.035	
40		A05.004.040	A05.005.040	A05.006.040	A05.008.040	A05.010.040	A05.012.040	A05.016.040	A05.020.040
45		A05.004.045	A05.005.045	A05.006.045	A05.008.045	A05.010.045	A05.012.045	A05.016.045	A05.020.045
50		A05.004.050	A05.005.050	A05.006.050	A05.008.050	A05.010.050	A05.012.050	A05.016.050	A05.020.050
55			A05.005.055	A05.006.055	A05.008.055	A05.010.055	A05.012.055	A05.016.055	A05.020.055
60			A05.005.060	A05.006.060	A05.008.060	A05.010.060	A05.012.060	A05.016.060	A05.020.060
65				A05.006.065	A05.008.065	A05.010.065	A05.012.065	A05.016.065	A05.020.065
70				A05.006.070	A05.008.070	A05.010.070	A05.012.070	A05.016.070	A05.020.070
80				A05.006.080	A05.008.080	A05.010.080	A05.012.080	A05.016.080	A05.020.080
90				A05.006.090	A05.008.090	A05.010.090	A05.012.090	A05.016.090	A05.020.090
100					A05.008.100	A05.010.100	A05.012.100	A05.016.100	A05.020.100
120					A05.008.120	A05.010.120	A05.012.120	A05.016.120	A05.020.120
130					A05.008.130	A05.010.130	A05.012.130	A05.016.130	A05.020.130
140					A05.008.140	A05.010.140	A05.012.140	A05.016.140	A05.020.140
150					A05.008.150	A05.010.150	A05.012.150	A05.016.150	A05.020.150
160					A05.008.160	A05.010.160	A05.012.160	A05.016.160	A05.020.160
180					A05.008.180	A05.010.180	A05.012.180	A05.016.180	A05.020.180
200						A05.010.200	A05.012.200	A05.016.200	A05.020.200

A15.xxx.xxx

WASHER :

Heat treated, tempered and burnished steel
Strength: 100 kg/mm²

TUBE :

Heat treated, tempered and ground steel
Ext. tolerance = h7
Longitudinal tolerance +0.1
-0

SCREW : Category 12.9

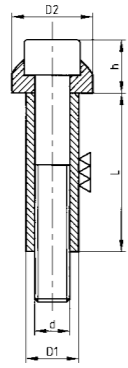

Assembly examples

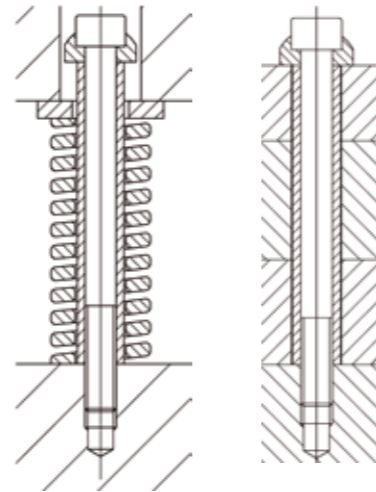

Ordering example

Shoulder screw - diameter: 15, length: 50

Please state: Ref. A15.015.050

D1	10	12.5	15	17.5	23
d	M6	M8	M10	M12	M16
D2	15	19	23	27	34
h	10	13	15	18	24
Maximum torque					
N/m	13	32	65	120	290
Maximum load					
daN	140	400	1000	1600	2400
Length	Reference				
20	A15.010.020				
25	A15.010.025				
30	A15.010.030	A15.012.030	A15.015.030		
35	A15.010.035	A15.012.035	A15.015.035		
40	A15.010.040	A15.012.040	A15.015.040	A15.017.040	
45	A15.010.045	A15.012.045	A15.015.045	A15.017.045	
50	A15.010.050	A15.012.050	A15.015.050	A15.017.050	A15.023.050
55	A15.010.055	A15.012.055	A15.015.055	A15.017.055	
60	A15.010.060	A15.012.060	A15.015.060	A15.017.060	A15.023.060
70		A15.012.070	A15.015.070	A15.017.070	A15.023.070
80		A15.012.080	A15.015.080	A15.017.080	A15.023.080
90			A15.015.090	A15.017.090	A15.023.090
100			A15.015.100	A15.017.100	A15.023.100
110				A15.017.110	A15.023.110
120				A15.017.120	A15.023.120

Material : Heat treated steel
Strength : 1200 N/mm²

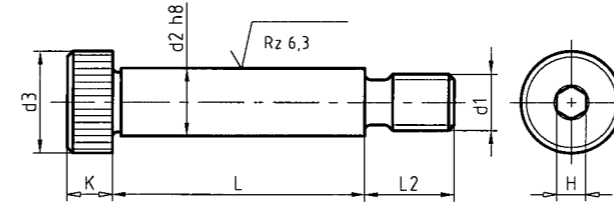

Assembly examples

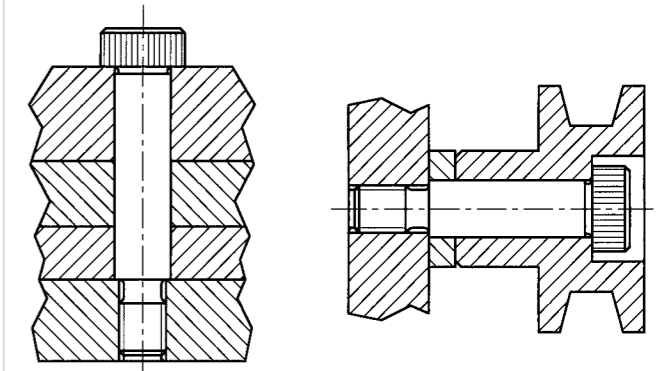

Ordering example

Shoulder screw - diameter: 10, length: 40

Please state: Ref. A17.010.040

d₂	6	8	10	12	16	20	24
d₁	M5	M6	M8	M10	M12	M16	M20
d₃	10	13	16	18	24	30	36
K	4.5	5.5	7	8	10	14	16
L₂	9.5	11	13	16	18	22	27
H	3	4	5	6	8	10	12
L₀^{+0.1}	Reference						
10	A17.006.010						
12	A17.006.012	A17.008.012					
16	A17.006.016	A17.008.016	A17.010.016	A17.012.016			
20	A17.006.020	A17.008.020	A17.010.020	A17.012.020			
25	A17.006.025	A17.008.025	A17.010.025	A17.012.025			
30	A17.006.030	A17.008.030	A17.010.030	A17.012.030	A17.016.030		
35	A17.006.035	A17.008.035	A17.010.035	A17.012.035	A17.016.035		
40	A17.006.040	A17.008.040	A17.010.040	A17.012.040	A17.016.040	A17.020.040	
45	A17.006.045	A17.008.045	A17.010.045	A17.012.045	A17.016.045	A17.020.045	
50	A17.006.050	A17.008.050	A17.010.050	A17.012.050	A17.016.050	A17.020.050	A17.024.050
55		A17.008.055	A17.010.055	A17.012.055	A17.016.055	A17.020.055	A17.024.055
60		A17.008.060	A17.010.060	A17.012.060	A17.016.060	A17.020.060	A17.024.060
65		A17.008.065	A17.010.065	A17.012.065	A17.016.065	A17.020.065	A17.024.065
70		A17.008.070	A17.010.070	A17.012.070	A17.016.070	A17.020.070	A17.024.070
80			A17.010.080	A17.012.080	A17.016.080	A17.020.080	A17.024.080
90				A17.012.090	A17.016.090	A17.020.090	A17.024.090
100				A17.012.100	A17.016.100	A17.020.100	A17.024.100
120					A17.016.120	A17.020.120	A17.024.120

Conforms to : DIN 6325 - AFNOR 27-475
 Material : Tool steel
 Hardness : 60 ± 2 HRc
 Tolerance : m6

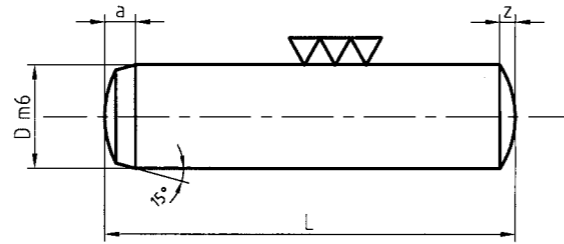

Ordering example

Dowel pin: D=8 L=50

Please state : Réf. A20.008.050

D	3	4	5	6	8	10	12	16	20
a	1,1	1,4	1,7	2,1	2,6	3	3,8	4,7	6
z	0,45	0,6	0,75	0,9	1,2	1,5	1,8	2,5	3
Length	Reference								
10	A20.003.010	A20.004.010	A20.005.010	A20.006.010					
12	A20.003.012	A20.004.012	A20.005.012	A20.006.012					
16	A20.003.016	A20.004.016	A20.005.016	A20.006.016					
18	A20.003.018	A20.004.018	A20.005.018	A20.006.018	A20.008.018				
20	A20.003.020	A20.004.020	A20.005.020	A20.006.020	A20.008.020				
24	A20.003.024	A20.004.024	A20.005.024	A20.006.024	A20.008.024	A20.010.024			
28	A20.003.028	A20.004.028	A20.005.028	A20.006.028	A20.008.028	A20.010.028			
32	A20.003.032	A20.004.032	A20.005.032	A20.006.032	A20.008.032	A20.010.032			
36		A20.004.036	A20.005.036	A20.006.036	A20.008.036	A20.010.036	A20.012.036		
40		A20.004.040	A20.005.040	A20.006.040	A20.008.040	A20.010.040	A20.012.040		
45			A20.005.045	A20.006.045	A20.008.045	A20.010.045	A20.012.045		
50			A20.005.050	A20.006.050	A20.008.050	A20.010.050	A20.012.050	A20.016.050	A20.020.050
55				A20.006.055	A20.008.055	A20.010.055	A20.012.055		
60				A20.006.060	A20.008.060	A20.010.060	A20.012.060	A20.016.060	A20.020.060
70					A20.008.070	A20.010.070	A20.012.070		
80					A20.008.080	A20.010.080	A20.012.080	A20.016.080	A20.020.080
90						A20.010.090	A20.012.090	A20.016.090	A20.020.090
100						A20.010.100	A20.012.100	A20.016.100	A20.020.100
120						A20.010.120	A20.012.120	A20.016.120	A20.020.120

Conforms to : DIN 7979 - AFNOR 27-475
 Material : Tool steel
 Hardness : 60 ± 2 HRc
 Tolerance : m6

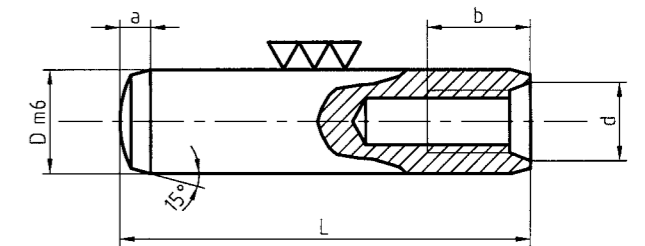

Ordering example

Dowel pin: D=8 L=50

Please state : Réf. A25.008.050

D	6	8	10	12	16	20
d	M4	M5	M6	M6	M8	M10
a	2,1	2,6	3,0	3,8	4,6	6,0
b	6	8	10	12	16	18
Length	Reference					
20	A25.006.020	A25.008.020	A25.010.020			
32	A25.006.032	A25.008.032	A25.010.032	A25.012.032		
40	A25.006.040	A25.008.040	A25.010.040	A25.012.040	A25.016.040	A25.020.040
50	A25.006.050	A25.008.050	A25.010.050	A25.012.050	A25.016.050	A25.020.050
60		A25.008.060	A25.010.060	A25.012.060	A25.016.060	A25.020.060
70		A25.008.070	A25.010.070	A25.012.070	A25.016.070	A25.020.070
80			A25.010.080	A25.012.080	A25.016.080	A25.020.080
100				A25.012.100	A25.016.100	A25.020.100
120					A25.016.120	A25.020.120

Material : C45 / 1.0503

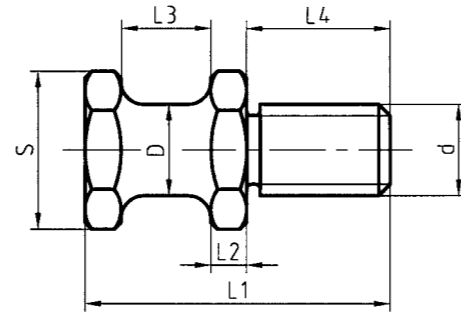

Ordering example:

Lifting lug with maximum load = 1500 daN

Please state: Réf. A30.010.030

D	Permissible load daN	d	L1	L2	L3	L4	S on flat	Reference
16	250	M16	58	5,5	20	28	24	A30.010.016
20	500	M20	68	8	20	32	30	A30.010.020
25	1000	M24	78	8	25	38	36	A30.010.024
32	1500	M30	95	10	32	45	41	A30.010.030
40	2500	M36	118	12	40	56	50	A30.010.036

Conforms to : DIN 580
Material : Hot-forged, deburred C15 steel

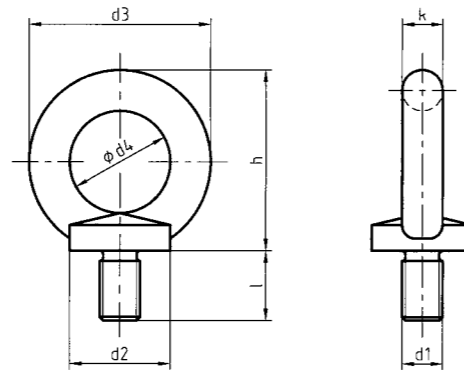

Ordering example

12 diameter collar eye bolt

Please state: Réf. A30.012.012

d1	Permissible load daN	d2	d3	d4	l	h	k	Reference
M8	140	20	36	20	13	36	8	A30.012.008
M10	230	25	45	25	17	45	10	A30.012.010
M12	340	30	54	30	20,5	53	12	A30.012.012
M16	700	35	63	35	27	62	14	A30.012.016
M20	1200	40	72	40	30	71	16	A30.012.020
M24	1800	50	90	50	36	90	20	A30.012.024
M36	5100	75	126	70	54	128	28	A30.012.036
M42	7000	80	144	80	63	147	32	A30.012.042

- High-strength suspension ring tested in accordance with DIN 5688-8
- Can be loaded in every direction - safety factor 4
- Can swivel under load
- Simple assembly with just a tapped hole
- Suitable for through holes
- Attractive and practical design
- Surface treatment: Red polymerised powder coating or electro-galvanised

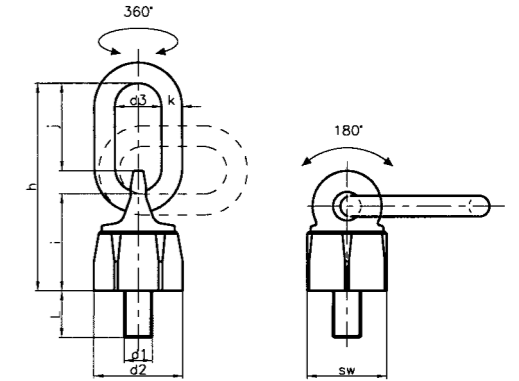

Ordering example

16 diameter swivel lifting ring

Please state: Réf. A30.013.016

d1	Permissible load Tonnes	d2	d3	h	i	j	k	L	SW	Reference
M12	0,6	42	35	105	45	51	10	21	36	A30.013.012
M16	1,3	48	35	114	54	49	10	30	41	A30.013.016
M20	2,0	64	35	135	65	56	13	33	55	A30.013.020
M24	3,5	81	40	172	87	68	18	40	70	A30.013.024
M30	5,5	99	50	220	105	93	22	50	85	A30.013.030

Material : C45 / 1.0503

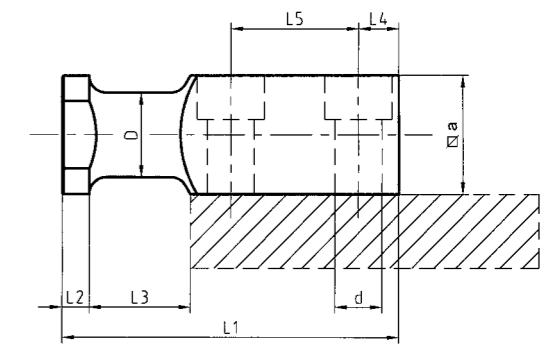

Ordering example

Lifter studs with maximum load = 2000 daN

Please state: Réf. A30.015.016

D	Permissible load daN	d for screw	Screw reference	L1	L2	L3	L4	L5	a	Reference
16	320	M8x30	A05.008.030	80	6	20	10	34	20	A30.015.008
20	630	M10x35	A05.010.035	90	8	25	10	37	25	A30.015.010
25	1250	M12x40	A05.012.040	100	8	30	12	38	35	A30.015.012
32	2000	M16x55	A05.016.055	120	10	32	16	46	40	A30.015.016
40	3200	M20x70	A05.020.070	140	10	40	18	54	50	A30.015.020

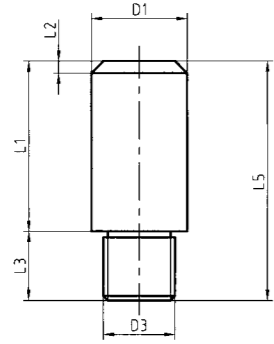

SHAPE A

Material 1.0503 / XC48

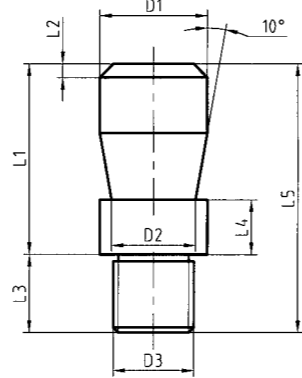

SHAPE B

Material 1.0503 / XC48

D1	D2	D3	L1	L2	L3	L4	L5	Shape A Reference	Shape B Reference
20	15	M16x1,5	40	3	18	12	58	A30.020.010	
25	20	M16x1,5	45	4	23	16	68	A30.020.020	A30.021.020
25	20	M20x1,5	45	4	23	16	68	A30.020.030	
32	25	M20x1,5	56	4	23	16	79	A30.020.040	
32	25	M24x1,5	56	4	23	16	79	A30.020.050	
40	32	M24x1,5	70	5	23	26	93	A30.020.060	A30.021.040
40	32	M30x2	70	5	23	26	93	A30.020.070	A30.021.060
50	42	M30x2	80	6	28	26	108	A30.020.080	A30.021.080

Conforms to : Standard NFE 63-132
 Material : According to AFNOR
 (French Association for Standardisation)
 specification
 NB. MABEC coding of components

Ordering example

Ø50 lifting bolt
 Please state: Réf. **BRM.050.V1**

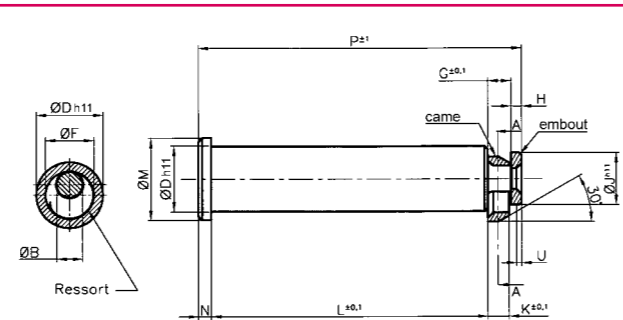

Dimensions without tolerances: ±0.25

Lifting capacity	ØD	ØB	ØF	G	H	ØJ	K	L	ØM	N	P	U	MABEC ref.	Order ref. no.
6 000 kg	32	12	22	11	5	25	10	132	40±0,8	6	154	2,5	P 953 254 770	BRM.032.V1
9 000 kg	40	16	28	13,75	6	32	12,5	170	50±0,8	8	197,75	3	P 953 255 870	BRM.040.V1
14 000 kg	50	20	36	17,60	8	40	16	212	63±1	10	247,60	4	P 953 256 670	BRM.050.V1
22 500 kg	63	25	45	22	10	50	20	265	80±1	12	309	5	P 953 257 470	BRM.063.V1

Material : Elastomer
 Hardness : 90 Shore A

Ordering example

Ø 6 mm compression pad
 Please state: Réf. **A50.006.000**

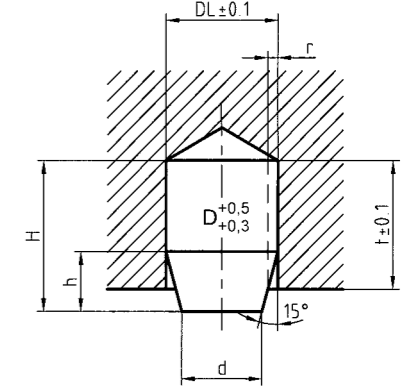

H	h	d	r	DL	t	P maxi (daN)	Reference
9,5	4,5	3,6	-	6	8	10	A50.006.000
15,5	7,5	6	1	10	13	45	A50.010.000
25	12	9,5	1,5	16	21	150	A50.016.000
25	10	18	2	24	21	300	A50.024.000
35	19	20	2,5	30	30	300	A50.030.000
32	14	24	3	32	26	1200	A50.032.000
40	16	30	3	39,5	34	2500	A50.040.000

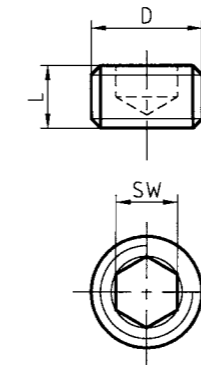

Application example

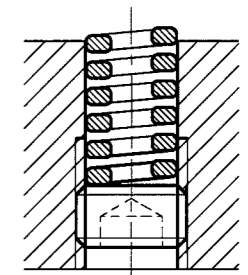

D	L	SW	Reference
M12x1,5	10	6	A32.012.010
M14x1,5	10	6	A32.014.010
M16x1,5	10	8	A32.016.010
M18x1,5	10	10	A32.018.010
M20x1,5	12	10	A32.020.012
M22x1,5	12	12	A32.022.012
M24x1,5	12	14	A32.024.012
M27x1,5	12	14	A32.027.012

INNOVATION

Guide and lifter kit made of a assembly of a band guide/lifter bloc, a lock washer and a screw.

The compression spring to be ordered separately.

Default value: $a=3$, other available upon request.

We do recommend a boring tolerance of H7.

Exemple de commande

Pour $C = 20$

Veuillez indiquer : Réf. **GIB.200**

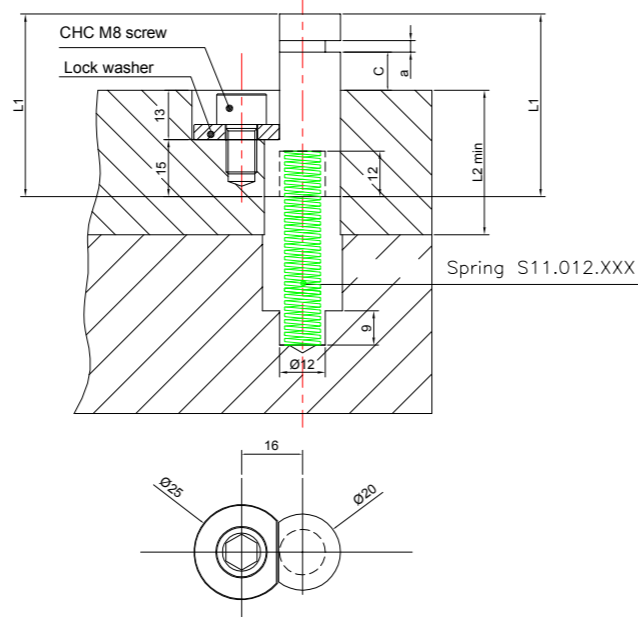
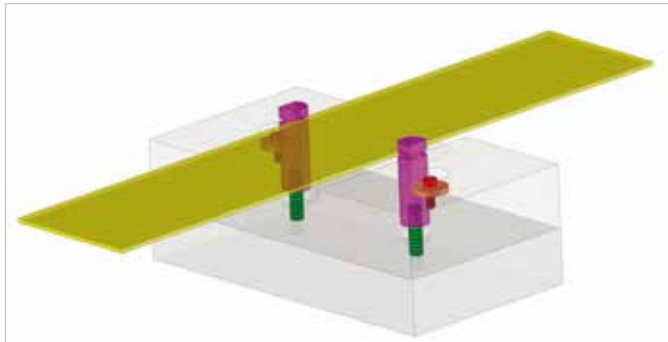

References	L1	L2 min minimum guiding	C	Spring advised not included	Lock washer included	Screw included
GIB.100	48	38	10	S11.012.051	GIB.005.025	A05.008.025
GIB.200	58	48	20	S11.012.064	GIB.005.025	A05.008.025
GIB.300	68	58	30	S11.012.076	GIB.005.025	A05.008.025

Notes section with horizontal dashed lines for writing.

You can access to our gas strippers and spring ejectors portofolio in refering to our gas spring catalog.